

# 4640E NA/Turbo

	SL4640E	SL4640E Turbo
<b>DIMENSIONS</b>		
Overall Operating Height (mm)	149" (3785)	149" (3785)
Height to Hinge Pin (fully raised) (mm)	115.5" (2934)	115.5" (2934)
Overall Height (to top of ROPS) (mm)	78" (1981)	78" (1981)
Ground Clearance to Chassis (mm)	7.5" (191)	7.5" (191)
Overall Length (mm)	122.8" (3119) w/66" bucket	122.8" (3119) w/66" bucket
Overall Length (w/o bucket)	89.8" (2281)	89.8" (2281)
Wheelbase (mm)	37.5" (953)	37.5" (953)
Dump Reach (full height) (mm)	27.6" (701)	27.6" (701)
Rollback at Ground	27°	27°
Dump Angle	40°	40°
Overall Width (mm)	63.5" (1613)	63.5" (1613)
Bucket Width (mm)	66" - 72" (1679 - 1829)	66" - 72" (1679 - 1829)
Clearance Circle (rear) (mm)	59.5" (1513)	59.5" (1513)
Clearance Circle (front, w/o bucket) (mm)	47" (1194)	47" (1194)
Clearance Circle (front, w/bucket) (mm)	74.5" (1892)	74.5" (1892)
Seat to Ground Height (mm)	37.5" (953)	37.5" (953)
Rollback at Full Height (mm)	86°	86°
Dump Height (mm)	89.5" (2273)	89.5" (2273)
Departure Angle	25°	25°
Standard Tire Size	10.00x16.5 HD	10.00x16.5 HD

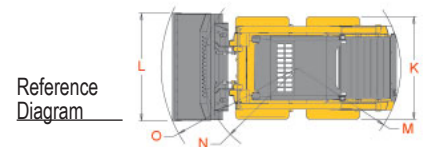
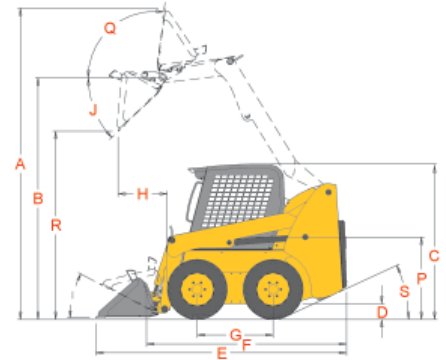

	Deutz	Deutz
<b>ENGINE</b>		
Make	Deutz	Deutz
Model	F3M2011	BF3M2011
Net Power (kW) @ rpm	46 hp (34) @ 2600	60 hp (45) @ 2600
Displacement (L)	142 cu.in. (2.3)	142 cu.in. (2.3)

<b>HYDRAULIC SYSTEM</b>		
Auxiliary Hydraulics - Standard (L/min)	19 gpm (72)	19 gpm (72)
High-Flow Hydraulics - Optional (L/min)	30 gpm (114)	30 gpm (114)
Filtration	3 micron	3 micron
Reservoir Capacity (L)	12 gal. (45)	12 gal. (45)

<b>ELECTRICAL SYSTEM</b>		
Battery	12-volt (950 CCA)	12-volt (950 CCA)
Starter (kW)	12-volt (2.3)	12-volt (2.3)
Alternator	95-amp.	95-amp.

<b>CAPACITIES AND WEIGHTS</b>		
Rated Operating Load (kg)	1550 lbs. (680)	1650 lbs. (748)
Rated Operating Load with opt. Counterweight (kg)	1700 lbs. (771)	1800 lbs. (816)
Tipping Capacity (kg)	3100 lbs. (1361)	3300 lbs. (1497)
Fuel Tank (L)	15 gal. (56)	15 gal. (56)
Travel Speed w/Joystick (km/h)	8.8 mph (14.2)	8.8 mph (14.2)
with 2-speed drive option (km/h)	14.0 mph (22.5)	14.0 mph (22.5)
Travel Speed w/o Joystick (km/h)	7.7 mph (12)	7.7 mph (12)
max. (km/h)	12.4 mph (20)	12.4 mph (20)
Operating Weight - approx. (kg)	6200 lbs. (2812)	6200 lbs. (2812)

The Gehl E-Series Skid Loaders feature enhanced performance and an expanded lineup of seven models, ranging from the compact 3640E through the NEW, top-of-the-line 7810E, the world's most powerful skid loader. These machines are a "must-have" for every task, whether you're a contractor, landscaper, renter, farmer, or just have a lot of work and not enough time.

Contact your nearest Gehl dealer for more information.

**GEHL**  
COMPACT EQUIPMENT FOR BIG RESULTS™

[www.gehl.com](http://www.gehl.com)

143 Water Street  
West Bend, WI 53095  
U.S.A.

Tel: 262-334-9461  
Fax: 262-338-7517

# 4640E

## STANDARD EQUIPMENT

- Air-conditioned Cab with Heater
- Fuel Level Gauge
- Engine Coolant Temperature Gauge and Indicator Light
- Hourmeter
- Oil Pressure Indicator Light
- Battery Charge Indicator Light
- Seatbelt Indicator Light and Buzzer
- Choice of four controls: T-Bar, Hand/Foot, Dual Hand or T-Bar Joystick
- Foot Throttle (T-Bar and Dual Hand only)
- Acoustical Material and Head liner
- Adjustable Operator Restraint Bar with Armrests
- ROPS/FOPS ISO Level II
- Skid Plate for Clean Out
- Interior Dome Light
- Hydraloc™ System – Brakes and Interlock for Starter, Lift Cylinders, Tilt Cylinders, Wheel Drives
- Dual-Element Air Cleaner with Visual Indicator
- Anti-Vandalism Rear Door
- Pre-Heat Starting Assist
- Servo-Controlled Hydrostatic Drive
- Lift Arm Support Device
- Self-Leveling Lift Action
- Dual Front and Rear Halogen Work Lights and Dual Tail Lights
- Bi-directional Auxiliary Hydraulics with Flat-Faced Couplers
- Powerview® Lift Arm
- All-Tach™ Attachment Mounting System: Two Lever (Manual)
- Engine Auto-Shutdown System

## OPTIONAL EQUIPMENT

- Upper-torso Restraint (required with 2-speed transmission)
- 3-inch Wide Seatbelt – Where Required by Law
- Sliding Side Windows
- Rear-View Mirror
- Adjustable Suspension Seat
- Impact-Resistant Front Door
- Front Door with Wiper
- Operator's Compartment Heater/ Defroster/Air Conditioner
- Audible Back-Up Alarm
- Strobe Light
- Bucket Bolt-On Cutting Edge Kits
- Four-Point Lift Kit
- Single-Point Lift Kit
- Hydraulic Couplers Kit
- Centrifugal Pre-Cleaner
- Engine Pan Heater
- 2-Speed Transmission
- Bi-directional High-Flow Auxiliary Hydraulics with Flat-Faced Couplers
- Hydraglide™ Ride Control System
- All-Tach™ Attachment Mounting System: Power-A-Tach
- Adjustable Suspension Seat
- Hydraulic Oil Filter Indicator Light
- Horn
- Spark Arresting Muffler



With a powerful Deutz diesel engine, the 4640E model has the power, speed, reach and visibility to get jobs done quickly. And the spacious, ergonomic operator's station maximizes productivity.

## BUCKETS AND CAPACITIES

Width	Description	Capacity	Weight	Rating
68" (1727 mm)	Dirt/Construction	15.3 ft³ (0.43 m³)	465 lbs. (211 kg)	1575 lbs. (714 kg)
65" (2286 mm)	Dirt/Construction	10.8 ft³ (0.31 m³)	310 lbs. (141 kg)	1529 lbs. (694 kg)
65" (2286 mm)	Dirt/Construction	14.7 ft³ (0.42 m³)	380 lbs. (172 kg)	1459 lbs. (662 kg)
67" (1702 mm)	Dirt/Construction with Spill Guard	14.5 ft³ (0.41 m³)	383 lbs. (174 kg)	1651 lbs. (749 kg)
72" (1829 mm)	Utility/Snow	32.5 ft³ (0.92 m³)	645 lbs. (293 kg)	1083 lbs. (491 kg)
65" (1657 mm)	Utility/Snow	18.6 ft³ (0.53 m³)	395 lbs. (179 kg)	1280 lbs. (581 kg)
69.5" (1765 mm)	Utility	15.5 ft³ (0.44 m³)	489 lbs. (222 kg)	1368 lbs. (621 kg)
67" (1702 mm)	Low Profile/Grading	14.5 ft³ (0.41 m³)	383 lbs. (174 kg)	1228 lbs. (557 kg)
15.75" (400 mm)	Forks with Backrest Rating per EN474-3	N/A	645 lbs. (293 kg)	1149 lbs. (521 kg)
19.68" (500 mm)	Forks with Backrest Rating per EN474-3	N/A	395 lbs. (179 kg)	1082 lbs. (491 kg)
24" (670 mm)	Forks with Backrest Rating per SAE 1197	N/A	492 lbs. (223 kg)	1033 lbs. (342 kg)

**GEHL**  
www.gehl.com

## SAFETY IS NO ACCIDENT.

Gehl Company reminds users to read and understand the operator's manual before operating any piece of equipment. Additionally, be sure all safety devices and shields are securely in place and functioning properly.

Gehl Company reserves the right to make changes in design or specifications at any time without notice or obligation.